

# Mecmesin

testing to perfection

## MultiTest-dV Tension and Compression Test Stand Operating Manual



## The Scope of This Document

This document refers to Mecmesin MultiTest-*dV* test stands operating with firmware version 3.0.10. It is essential that you familiarise yourself with the contents of this manual and the separate 'Guide to Safe Use of Mains Powered Test Systems' before attempting to operate your MultiTest-*dV* Test System.

You may also need to refer to these documents:

- 431-957** Long Travel Extensometer Installation Guide
- 431-955** VectorPro™ for Mecmesin Test Stands and Instruments
- 431-213** Advanced Force Gauge (AFG Mk4) Operating Manual
- 431-398** Guide to Safe Use of Mains Powered Test Systems

### Important

This user manual covers the operation of MultiTest-*dV* force test stands in conjunction with the use of Mecmesin digital Advanced Force Gauges, ELS devices and extensometers. Operation of gauges and extensometers is covered in separate manuals for these products.

For operating in conjunction with Vector Pro™, see the manual 431-955, *VectorPro™ for Mecmesin Test Stands and Instruments*.

2019 © Mecmesin Ltd, supplied with Mecmesin test systems and not for redistribution

Part no. 431-459-07

# Contents

---

<b>1. Items Supplied with the Test Stand</b>	<b>5</b>
Accessories	5
<b>2. MultiTest-dV System Diagram</b>	<b>6</b>
<b>3. MultiTest-dV - Dual Functionality</b>	<b>7</b>
3.1. Identifying a Mark 2 MultiTest-dV	7
3.2. Functionality Differences	8
3.3. Switching dV Modes	9
3.4. License Keys	10
<b>4. Initial Setup</b>	<b>11</b>
4.1. Unpacking the Stand	11
4.2. Lifting the Test Stand	11
4.3. Environment Conditions	11
4.4. Mains Power Supply	12
4.5. Fuse Specification	12
4.6. Fitting the Feet to the Stand	13
4.7. Bolting the Test Stand to the Work Surface	14
4.8. Fitting and Connecting an AFG	15
Connecting an AFG to the MultiTest-dV	16
AFG communication settings	16
4.9. ELS - Enhanced Load Sensor	18
4.10. Fitting an ELS to a Test stand	19
Connecting an ELS to the MultiTest-dV	20
4.11. Connect the Test Stand to a PC (VectorPro Users Only)	20
Cable Management	20
4.12. Attaching Grips and Fixtures	21
4.13. Setting the Limit Stops	22
4.14. Test Stand States	22
<b>5. Front Panel Controls</b>	<b>23</b>
Emergency Stop Button	23
Multi-function Scroll Wheel Control	23
MultiTest-dV Display Panel	25
On-Screen Icons	25
<b>6. Automatic ELS Firmware Update</b>	<b>28</b>

Step 1 - Connect an ELS Device	28
Step 2 - Starting the Upgrade	28
Step 3 - Flashing the Device	29
<b>7. MultiTest-dV Settings</b>	<b>31</b>
<b>7.1. MultiTest-dV Settings - dV Operation</b>	<b>31</b>
Settings: Jog settings	31
Settings: Units	32
Settings: Edit Test	32
Settings: PIN Code	39
Settings: Languages	39
Settings: Information	39
<b>7.2. MultiTest-dV Settings - dV(u) Operation</b>	<b>40</b>
Settings: Jog settings	40
Settings: PIN Code	40
Settings: Information	40
<b>8. Rear Connectors Panel</b>	<b>41</b>
<b>9. MultiTest-dV Specification</b>	<b>42</b>
<b>10. MultiTest-dV Dimensions</b>	<b>43</b>
MultiTest-dV 2.5kN Dimensions	43
MultiTest-dV 1.0kN Dimensions	44
MultiTest-dV 0.5kN Dimensions	45
<b>11. Declaration of Conformity</b>	<b>46</b>
<b>12. Change Log</b>	<b>47</b>
2.0.12 - New Features	47
2.0.12 - Bug Fixes	47
3.0.2 - New Features	47
3.0.2 - Bug Fixes	48
3.0.3 - New Features	48
3.0.3 - Bug Fixes	48
3.0.6 - New Features	48
3.0.6 - Bug Fixes	48
3.0.7 - New Features	48
3.0.7 - Bug Fixes	48
3.0.8 - New Features	49
3.0.8 - Bug Fixes	49
3.0.10 - New Features	49
3.0.10 - Bug Fixes	49
<b>13. Test Stand Firmware/ Software Compatibility Table</b>	<b>50</b>
<b>14. Operator Notes</b>	<b>51</b>

# 1. Items Supplied with the Test Stand

---

When ordering a MultiTest-*dV* test stand the following components are supplied:

- MultiTest-*dV* test stand (0.5, 1.0 or 2.5 kN),
- Dovetail gauge bracket (for fitting a gauge to the crosshead),
- Allen key for tightening crosshead to gauge bracket,
- Mains cable,
- Document: A Guide to Safe Use of Mecmesin Mains Powered Test Systems,
- Document: MultiTest-*dV* Compression and Tension Test Stands, Operating Manual,

## Accessories

For a full range of digital force gauges, ELS devices, extensometer and accessories, please go to the Mecmesin website [www.mecmesin.com](http://www.mecmesin.com), or your local distributor, as listed on the back cover.

- For connection of the stand to your computer, a Mecmesin supplied 2m USB B to USB A cable communications cable is required (part no. 351-093),
- When using a Mecmesin Advanced Force Gauge (AFG) use communications cable part no. 351-092 to connect the gauge to the MultiTest-*dV*,

## 2. MultiTest-dV System Diagram

---

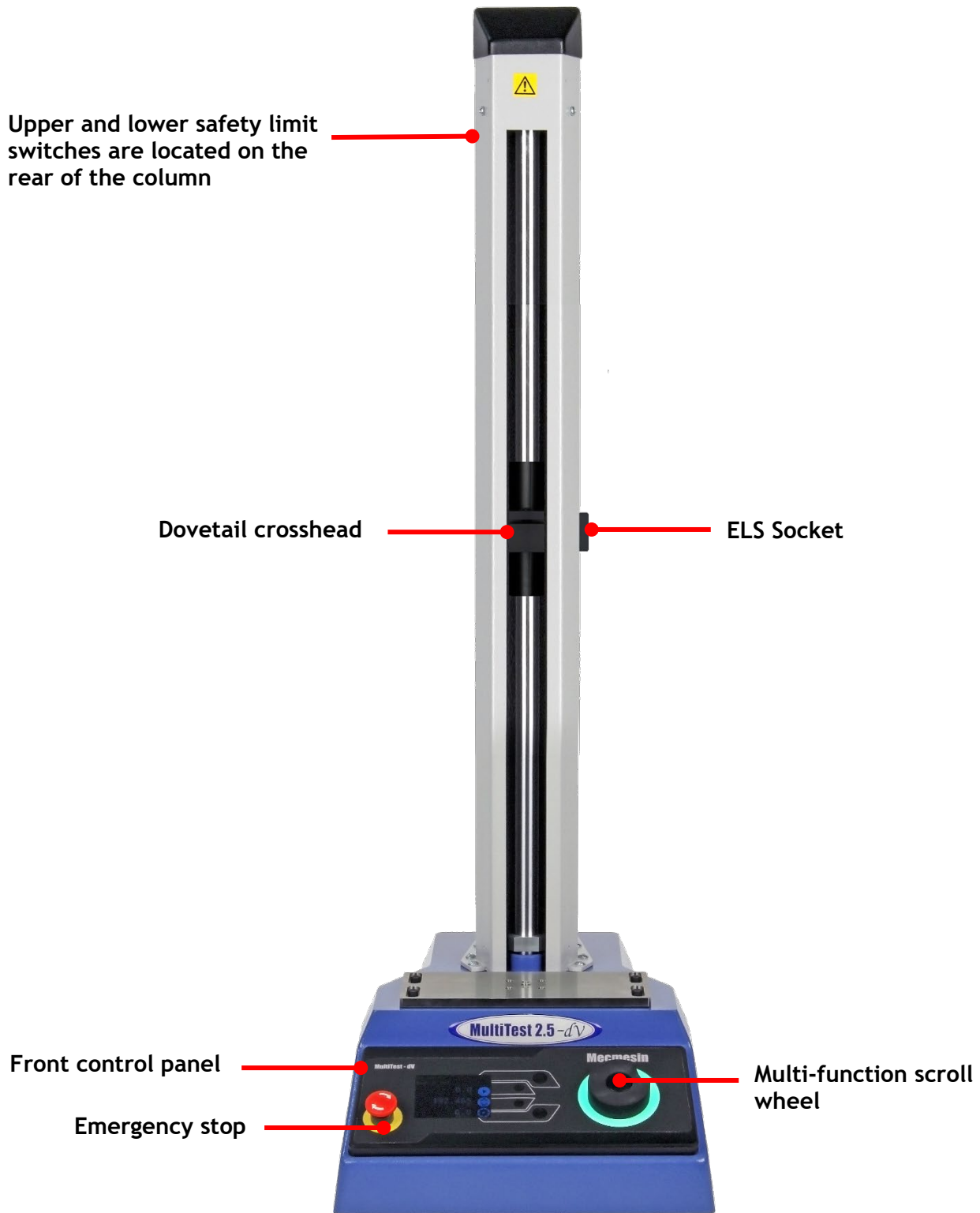

## 3. MultiTest-*dV* - Dual Functionality

---

MultiTest-*dV* Mark 2 test stands, with firmware version 3.0.2 and above, can operate in both standard *dV* mode and also *dV(u)* mode to allow support of ELS and extensometry devices, in conjunction with VectorPro 5.1.0.0 or later.

By default all MultiTest-*dV* test stands are supplied in *dV* mode, to switch the test stand to *dV(u)* mode both VectorPro and a *dV(u)* license key are required, these can both be ordered separately from your local Mecmesin distributor.

### 3.1. Identifying a Mark 2 MultiTest-*dV*

Compatible Mark 2 MultiTest-*dV* test stands are identified through two key elements:



All Mark 2 MultiTest-*dV* test stands have an ELS port (pictured above) located halfway up the column shroud on the right-hand side.

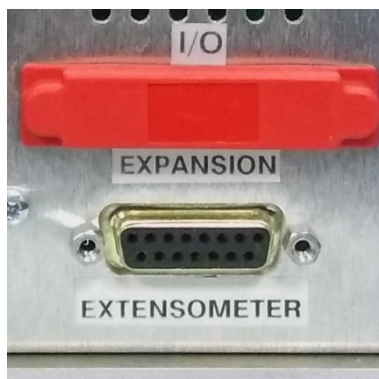

Located on the rear of the test stand is also an extensometer port, this is not present on earlier Mark 1 test stands.

### 3.2. Functionality Differences

The table below highlights features unique to each of the MultiTest-*dV*'s operating modes:

In <i>dV</i> Mode	In <i>dV(u)</i> Mode
Supports AFG/AFTI gauges only	Supports ELS devices only
Supports stand-alone testing option	VectorPro required for all testing
Supports cyclic testing	Extensometer support
Single operation	Multiple configurable operations within VectorPro
Force limit control	SDC support
Suitable for basic product testing	Suitable for basic material testing

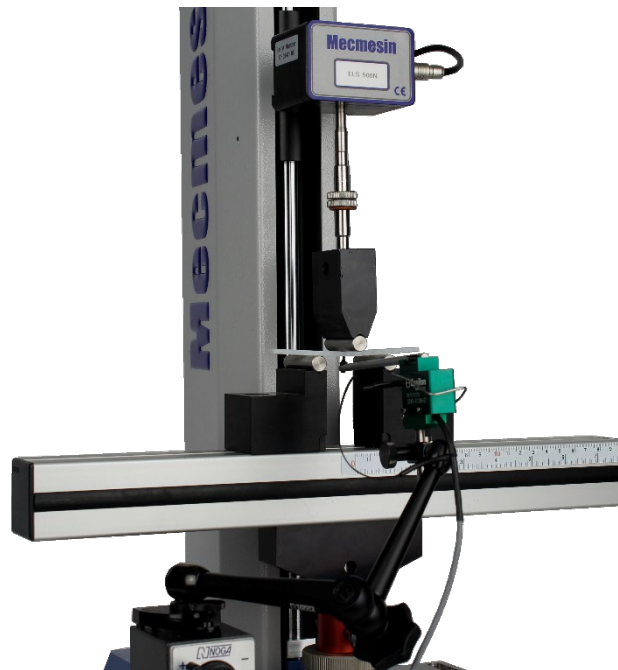

▲ A MultiTest-*dV* 2.5kN in *dV(u)* mode performing a 3-point bend, using an ELS 500N and deflectometer

### 3.3. Switching *dV* Modes

To switch to *dV(u)* mode you require a *dV(u)* key, a test stand with firmware version 3.0.2 or later and VectorPro 5.1.0.0 or later. The *dV(u)* key is a separate accessory and can be purchased from your local Mecmesin agent.

The key is linked to an individual test stand. It is crucial when ordering the key that you supply the test stand's serial number.

To switch your stand into *dV(u)* mode first open VectorPro. Once the workspace screen is displayed, click the USB icon located in the top left of the screen (circled in red below). Next, click the button highlighted in green in the image below, if a corresponding *dV(u)* key is present the stand will enter *dV(u)* mode.

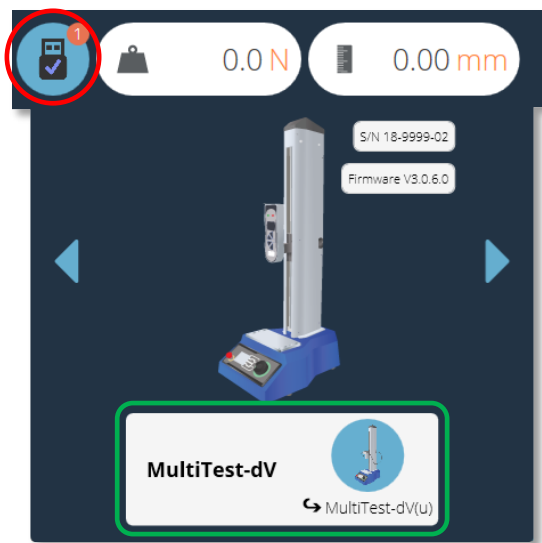

Pressing the button highlighted, in green above, switches the stand into *dV(u)* mode. In the screenshot above the stand is currently in *dV* mode, this is illustrated by the AFG connected to the stand and by the stand name located within the switch button.

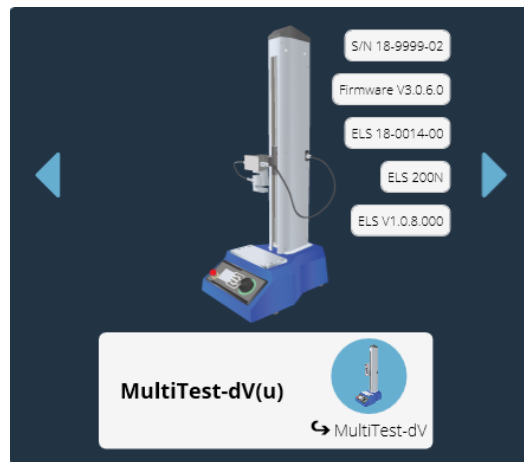

The image above shows the device in *dV(u)* mode, this is illustrated by the connected ELS in the image, as well as the ELS device information in the main panel.

To switch from  $dV(u)$  to  $dV$  mode open the device information panel within VectorPro and click the switch located at the bottom of the panel (Shown below).

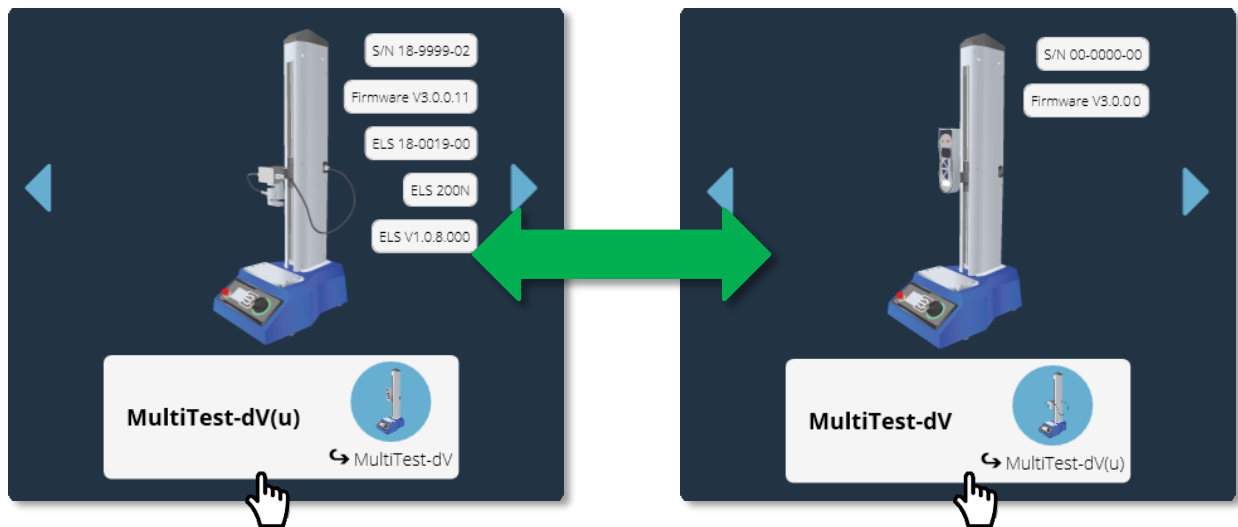

▲ Click the test stand switch located in the information panel to swap between  $dV$  and  $dV(u)$  mode

### 3.4. License Keys

A VectorPro Lite license key is required to run  $dV$  tests within VectorPro, this key is not required when testing in  $dV(u)$  mode but you do require a  $dV(u)$  key to switch the stand from  $dV$  mode to  $dV(u)$  mode.

## 4. Initial Setup

---

### 4.1. Unpacking the Stand

When you first receive the stand, please check that there is no visible damage to the packaging. If there is any sign that the packaging or the test stand itself has been damaged, please contact Mecmesin or your authorised distributor immediately. Do not use the stand until you have done so.

We strongly recommend that the packaging is retained, as this can be useful if the machine needs to be returned for calibration or shipped between sites.

**Items Supplied** with the Test Stand lists items that should be included with your test stand. Please contact Mecmesin or your authorised distributor if any items are missing or damaged.

### 4.2. Lifting the Test Stand

The unpackaged weight of the test stand is given in the Specification table at the back of this manual. Do not try to lift heavy loads unaided.

### 4.3. Environment Conditions

In line with BS EN 61010-1 it is recommended that your Mecmesin MultiTest-*dV* test stand is operated in an environment that matches the following conditions:

- Indoor use only. Recommended to be operated in a lab environment.
- Altitude up to 2 000 m,
- Temperature range between 10 °C to 35 °C. Please note that the instrument should not be used for long durations at higher temperatures.
- The maximum relative humidity is 80 % for temperatures up to 31 °C decreasing linearly to 50 % at 40 °C. It is crucial that the surrounding environment does not cause water to form on the device.
- Mains supply voltage fluctuations up to a maximum of  $\pm 10$  % of the nominal voltage.
- The environments should also take considerations of excessive dust or metal particulates as ingress of these into the device can cause damage to the system.

## 4.4. Mains Power Supply

MultiTest-*dV* test stands can be used on 110–120 or 220–240 Vac 50–60 Hz supplies. The rear fuse carrier is set for your local requirement but is reversible, so should you replace a fuse, the correct local voltage must be selected.

The voltage that is selected is indicated by which the arrow is pointing to the white line located at the bottom of the device. This is illustrated in the image below, shown within the red circle:

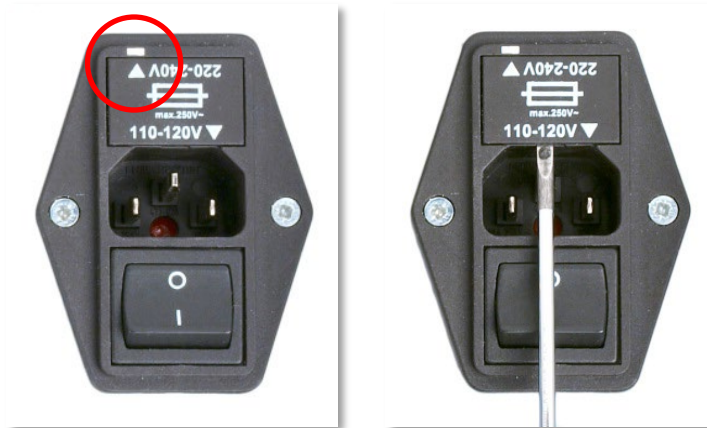

▲ Removing the fuse holder

## 4.5. Fuse Specification

MultiTest-*dV* test stands use two 2A - Speed T, 5 x 20mm fuses. If replacing a blown fuse, replace only the fuse on the active side of the inlet filter with the fuse specified above, or equivalent.

If you are in doubt, please contact your local Mecmesin support agent for more information.

## 4.6. Fitting the Feet to the Stand

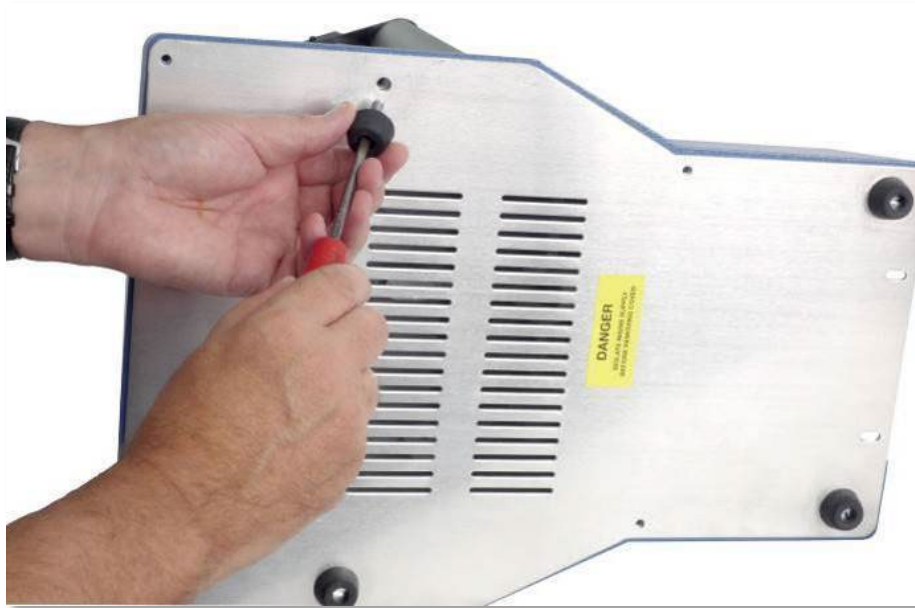

### ▲ Fitting rubber feet to the base of the test stand

The MultiTest-*dV* 2.5kN is supplied with four rubber feet. Support the stand and fit the four rubber feet to the base of the stand using an appropriate screwdriver.

For MultiTest-*dV*, 0.5kN and 1.0kN test stands it is recommended that the system is mounted to a suitable work surface using the supplied bench mount adapters. Please see the next section for more information.

## 4.7. Bolting the Test Stand to the Work Surface

To comply with European regulations and ensure the safe use of the equipment, single column stands should be secured to the bench as follows:

Test Stand Capacity (kN)	Height (Mm)	Feet/Fixing Supplied	Bolting Recommended
0.5	1616	Anchor brackets	Yes
1	1416	Anchor brackets	Yes
2.5	941	Rubber feet	No

The extended-length test stands (MultiTest 0.5-*dV* and MultiTest 1-*dV*) are supplied with base anchoring brackets to allow the test stands to be bolted to a bench.

Screw the anchoring brackets to the four positions on the base plate of the MultiTest 0.5-*dV* or 1-*dV* using the M6 screws provided (Shown below). Secure the test stand to the bench using suitable fasteners.



▲ MultiTest 0.5-*dV* and 1-*dV* are supplied with anchoring brackets

## 4.8. Fitting and Connecting an AFG

The MultiTest-*dV* has a dovetail bracket attached to the moving crosshead; this is used to mount AFG devices.

To fit an AFG first, attach the AFG mounting bracket (part no. 432-427) to the back of a Mecmesin AFG or AFTI digital force gauge. Then slide the gauge sideways onto the dovetail and secure it by tightening the dovetail screw with an Allen key.

To prevent damage, do not over-tighten the grub screw in the dovetail when a gauge bracket is not present.



▲ Tightening the dovetail when mounting the force gauge

**Note:** Take care when handling lower capacity AFGs, as damage can easily occur from mishandling.

It is also essential to ensure that the attached grips and fixtures do not overload the gauge. If in doubt, please check the weight of any addition grips and fixtures before fitting these.

## Connecting an AFG to the MultiTest-dV

A Mecmesin AFG digital force gauge is connected to the test stand using cable part no. 351-092. Connect the 15-pin D connector to the top socket of the AFG, and the opposite end of the cable to the RJ11 plug located on the rear of the stand:

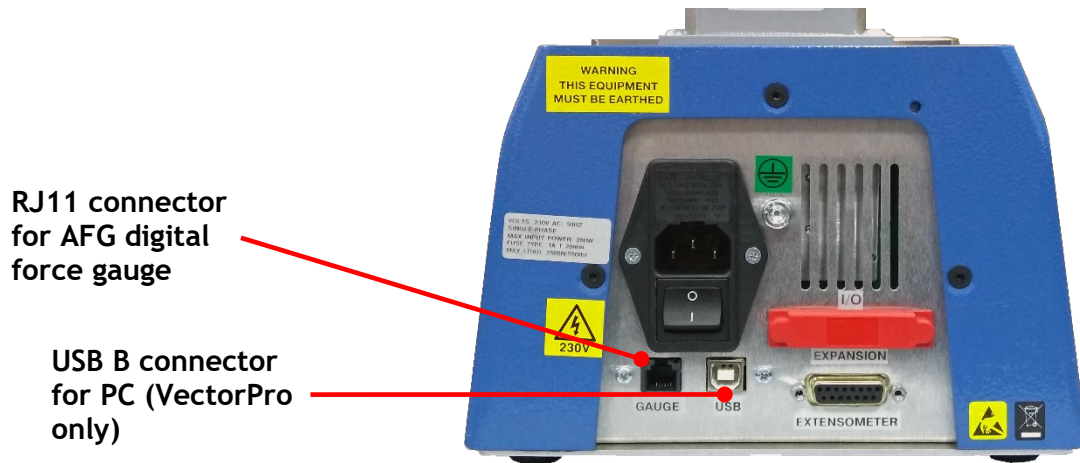

▲ Rear view of MultiTest-dV

## AFG communication settings

To achieve communication between a MultiTest-dV test system and an AFG gauge you need to apply the correct settings within the AFG's communication menu. Use the following steps to configure the AFG:

1. Hold **UNITS MENU** on the AFG until the main menu is displayed →

2. Press **UNITS MENU** once until you are on page 2 →

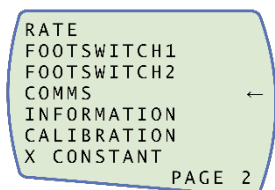

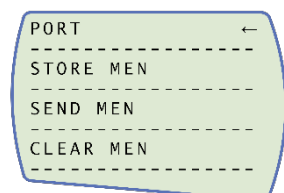

3. Scroll down using the **ZERO DOWN** button, then **RESET ENTER** press to select the "COMMS" menu →

4. Now press **RESET ENTER** on port →

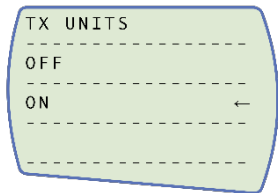

5. Set TX Units On press  →



6. Set TX Sign On press  →

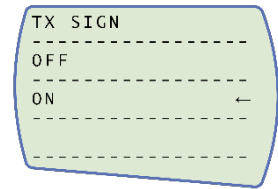

7. Set 115200, press  →

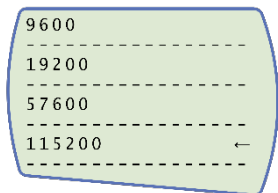

8. Set CR LF press  →

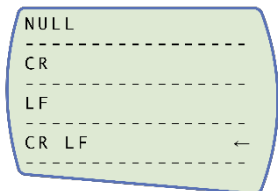

9. Ensure the line delay is set to 0 press  →

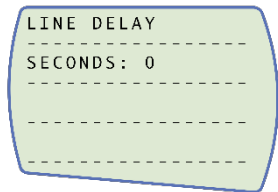

10. Ensure TX threshold is set to 0 press  →

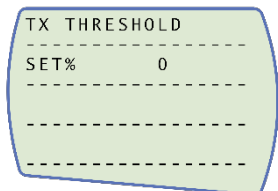

11. Set RS232 press  →

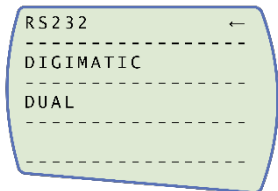

12. Then press  twice to return to the primary measurement screen.

**Note:** If using the stand in conjunction with VectorPro please ensure that the units selected on the gauge match the unit selected within the software.

## 4.9. ELS - Enhanced Load Sensor

Enhanced load sensors or ELS for short, are smart devices used to capture load readings for MultiTest-*dV* test stands operating in *dV(u)* mode.

All calibration information is held in the individual load cell meaning they can be swapped from system to system and the calibration will follow.

These load cells are available in a range of sizes and designs to best suit your requirements. See the **MultiTest-*dV* Specification** of this document for details relating to capture rate and accuracy.



▲ A selection of enhanced load sensors (Not all ELS devices shown are compatible with MultiTest-*dV* test stands)

## 4.10. Fitting an ELS to a Test stand

MultiTest- $dV$  test stands with  $dV(u)$  mode enabled use Mecmesin ELS devices to capture load readings.

To fit an ELS to the test stand slide the load cell sideways onto the dovetail and tighten the grub screw (circled below in red) located in the dovetail using a suitable Allen key.

To prevent damage, do not over-tighten the grub screw in the dovetail when a gauge bracket is not present.



▲MultiTest- $dV$  Dovetail, note the grub screw circled in red

**Note:** Take care when handling low capacity ELSs such as a 5N cell, as damage can easily occur from mishandling.

It is also vital to ensure that the attached grips and fixtures do not overload the ELS. If in doubt, please check the weight of any addition grips and fixtures before fitting these.

## Connecting an ELS to the MultiTest-dV

ELS devices connect to MultiTest-dV test stands using a 6-pin connector cable, this connects to the communication ports located on the side of the ELS and the test stands column, as seen in the image below.



▲ Connecting the 6-pin plug to the ELS

As enhanced load sensors are ‘smart’ devices all calibration and capacity information is passed to the stand automatically as the sensor is connected.

### 4.11. Connect the Test Stand to a PC (VectorPro Users Only)

If you are using VectorPro software, connect the USB B port, located on the test stand, to the accompanying PC using cable part no. 351-093.



Important! Please install VectorPro software on your desired PC before connecting the test stand to your computer. Once the software is installed and the stand is connected, the stand will show as connected. This is shown in the image to the left.

## Cable Management

It is essential that no cables interfere with the controls or any moving parts. Failure to do so could lead to injury or damage to the equipment.

## 4.12. Attaching Grips and Fixtures

For flexible attachment of a variety of accessories, and improved alignment, the MultiTest-*dV* is fitted with an anvil plate to accept fixtures with different screw threads as well as fixing points for a standard 20mm QC adapter.

This anvil plate is attached with four bolts using an Allen key. For alignment, the anvil plate can be loosened, moved forwards or back, and the bolts retightened.



▲ Anvil plate located at the base of the MultiTest-*dV*

Upper grips and accessories are attached directly to the ELS device being used.

QC adapters are available and can be fitted directly to the anvil plate or through a Mecmesin LTE-700 extensometer.

## 4.13. Setting the Limit Stops

Limit stops help prevent damage to load cells and fixtures by stopping the crosshead movement before the moving fixtures come into contact with static parts of the stand. Their positions are adjusted after the fitting of fixtures and test samples.

There are two manually set limit stops. These are set by loosening the thumbscrew, moving the stop to a new position and retightening. When the crosshead meets a stop, it activates a switch. This stops the crosshead movement at an upper or lower limit.

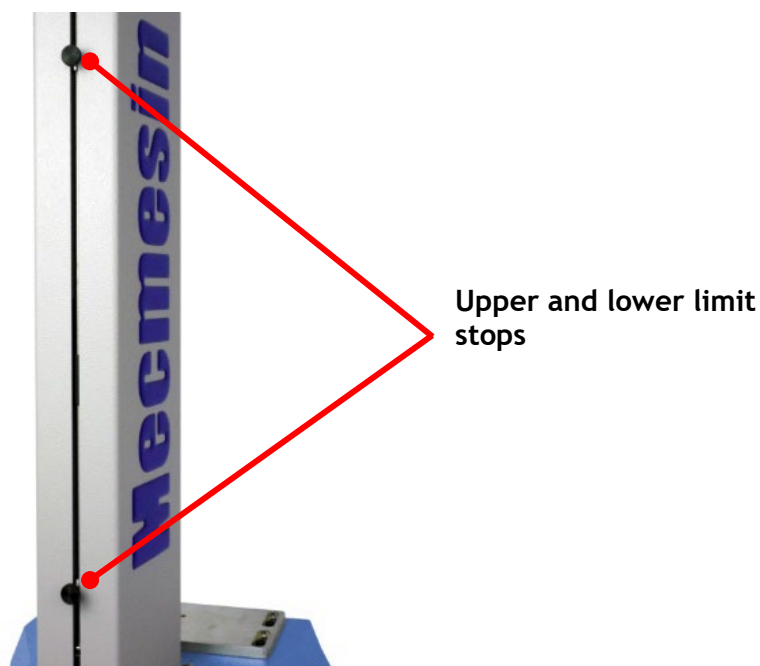

▲ Limit stops on a MultiTest-dV

**Note:** Limit switches are also used to set cyclic test start and end positions (page 37).

## 4.14. Test Stand States

The test stand can be in one of five states:

1. Test readiness - ready to start, or complete,
2. Testing - test operation sequence is running,
3. Stopped - test interrupted or emergency stop pressed,
4. Jog mode - for jogging or positioning the crosshead manually,
5. Settings menu - for adjusting your test stands settings,

In each state, the selector buttons have functions described by the on-screen icons.

## 5. Front Panel Controls

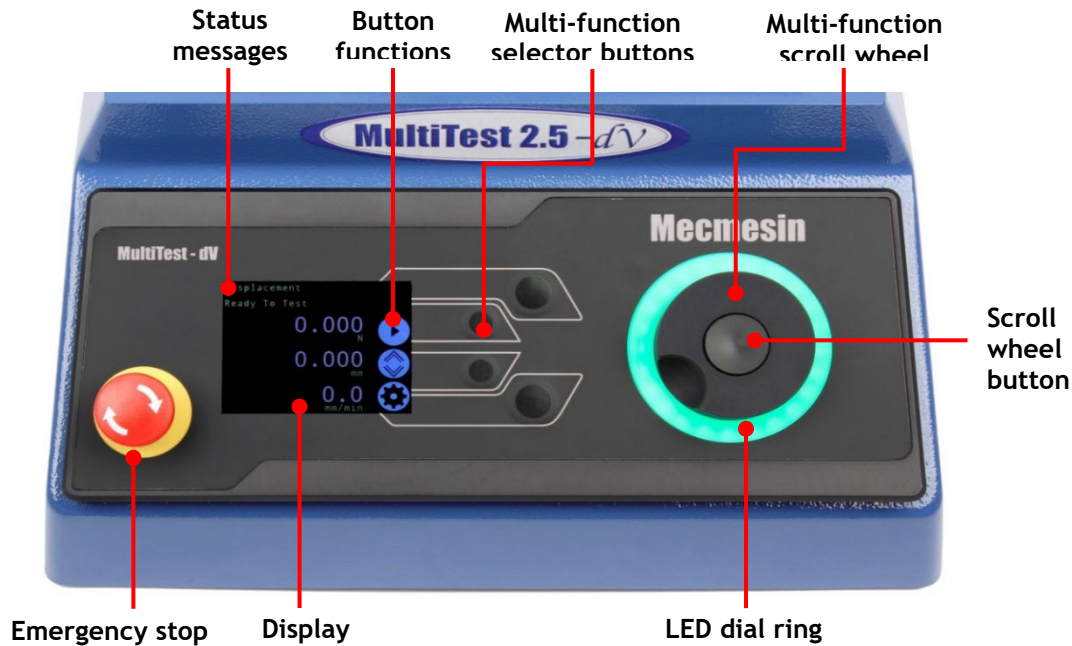

### Emergency Stop Button



Push to stop the crosshead movement. Rotate the button to release it and resume crosshead control. If pressed during a test, do not restart a test, ensure you remove any residual force using the test stand's jog controls.

### Multi-function Scroll Wheel Control

#### Scroll Wheel Colours

The lights surrounding the wheel illuminate in three colours, indicating the status of the test stand:



**Green Light**

**Pulsating:** Ready to start test  
**Rotating:** Scrolling through a menu  
**Flashing:** Test Completed



**Amber Light**

**Static:** In Jog Mode  
**Rotating:** Crosshead moving



**Red Light**

**Static:** Test stopped/limit triggered

## Jog Mode

When in jog mode the wheel drives the crosshead up (clockwise turn) or down (anticlockwise turn). This method offers more variable control when compared to the two fixed-speed jog control buttons (circled in red below).

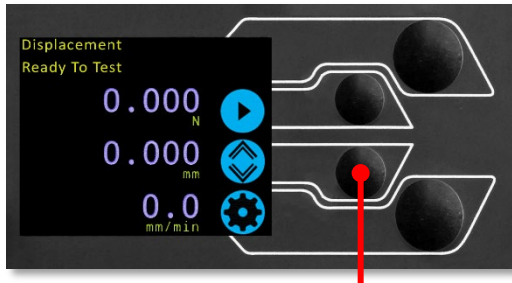

Enter jog mode

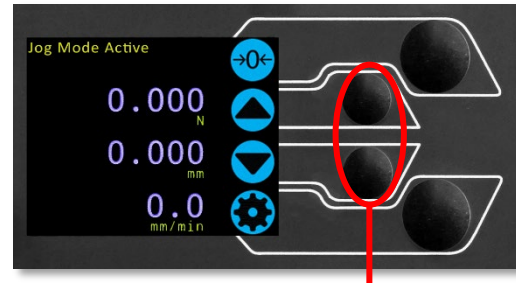

Jog control buttons

The scroll wheel can also be used as a speed controller. The jog buttons move the crosshead at the set speeds (configured in the 'Jog Settings' menu picture below). Rotating the wheel clockwise while holding a jog button increases the speed and rotating the wheel anticlockwise while holding a jog button decreases the speed.

MultiTest-*dV* test stands also feature a precision jog mode, rotating the scroll wheel while holding the central scroll wheel button moves the test stand at its minimum speed; this is useful when fitting specimens into grips for example.

## Navigational Control

When in a menu, the scroll wheel cycles through the options and their values. This is an alternate navigational option to using the up and down arrow buttons.

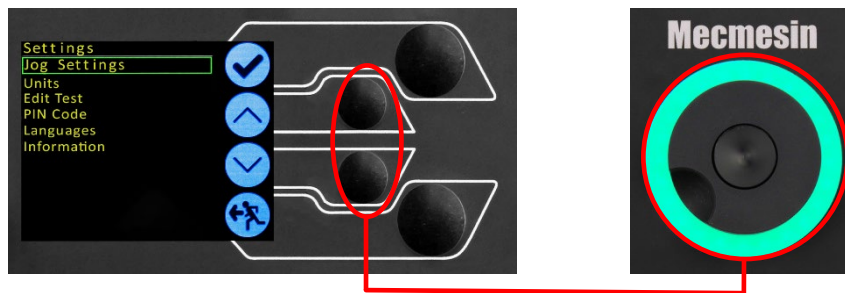

Menu: operates with buttons or wheel

## Central Button

The central button is used to confirm a menu selection. It is equivalent to the tick button.

It can also be used to activate fine jog control, rotating the scroll wheel while holding the central button in jog mode moves the test stand at its minimum speed.

## MultiTest-dV Display Panel

The display indicates the stand's status, displays live values and is used to configure the test stands settings.





The purpose of the four multi-function buttons is indicated on screen by an adjacent icon. Below is an image showing a typical example of the on-screen icons in relation to the physical buttons.







## On-Screen Icons

On-screen icons vary depending on the current state of the test stand and what functions the physical buttons perform at that point. Below are reference tables to help explain the icon definitions, in relation to the test stand state.





### 1. Test Readiness

Icon	Action
	No AFG connected / No ELS connected (if in <i>dV(u)</i> mode).
	Start the test sequence.
	Go to jog mode.
	Go to settings.





## 2. Testing

Icon	Action
	Pause test: This stops crosshead movement, leaving the stand in a state of test readiness. The message is 'Interrupted: User' and the play button is displayed as well as the stop button.
	Emergency stop button pushed: Message: 'Emergency Stop!!!'. Release the emergency stop to regain control and remedy the situation before resuming testing. Note there is no on-screen icon for the emergency stop.
	Upper limit switch triggered: The crosshead has reached the upper travel limit, as set by the MultiTest-dV's limit switches, and stopped. Further travel in this direction is prevented.
	Lower limit switch triggered: The crosshead has reached the lower travel limit, as set by the MultiTest-dV's limit switches, and stopped. Further travel in this direction is prevented.





## 3. Stopped

Icon	Action
	Continue test sequence.
	Stop test: This ends the test at this point
	Move to the home position (start position from the beginning of the previous test). This icon is only visible after pressing the stop
	Exit to the test ready screen, leaving the crosshead in its current position.

## 4. Jog Mode

Icon	Action
	Zero (tare) all system values.
	Move the crosshead upward at the set jog speed.
	Move the crosshead downward at the set jog speed.
	Crosshead has reached an upper limit (load signal from a connected gauge, set to Stop, or a limit switch) and stopped.
	Crosshead has reached a lower limit (load signal from a connected gauge, set to Stop, or a limit switch) and stopped.

## 5. Settings Menu

Icon	Action
	Confirm selection (or press the scroll wheel button).
	Navigate up a menu selection or value (or turn the wheel clockwise).
	Navigate down a menu selection or value (or turn the wheel anticlockwise).
	Go back to the previous screen.

## 6. Automatic ELS Firmware Update

---

MultiTest-*dV* test stands with firmware 3.2.0.0 and above operating in *dV(u)* mode can update the firmware of any attached ELS device. This feature is managed through the front panel and ensures that the latest firmware version is loaded to the ELS device.

### Step 1 - Connect an ELS Device

To start the update connect the ELS to your test system and then switch the test stand on.



**Note:** Analogue short travel extensometers can also be updated in a similar method, plug the extensometer device into the corresponding connector on the rear of your MultiTest-*dV* to update the device.

### Step 2 - Starting the Upgrade

Once the stand has powered on you the following screen will appear:

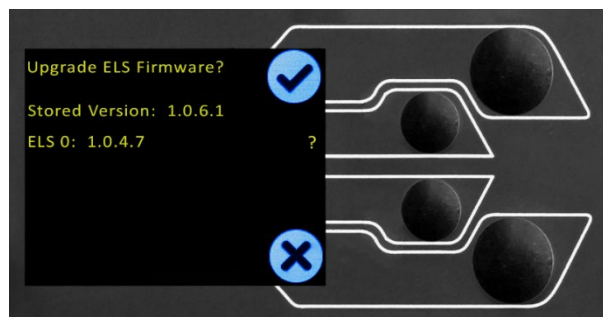

The new 'Stored' firmware is listed at the top of the display and the current ELS firmware is displayed below. In this instance the current firmware for the ELS is 1.0.4.7, starting the update will flash the device to version 1.0.6.1.

**Note:** If you press the 'Cross' icon the upgrade can be started manually later by opening the information screen located within the settings menu and scrolling to the ELS firmware version. This setting will have a '\*' next to it, pressing the 'tick' icon will open the firmware upgrade screen pictured above.

If more than one ELS is connected (e.g. a load cell and a short analogue extensometer) the additional device will be listed below ELS 0. To start the update of the first ELS device press the 'tick' icon.

### Step 3 - Flashing the Device

The flashing of the device is carried out automatically and progresses through several stages. It is crucial that the test stand is not turned off or disconnected. Disconnection of the ELS could lead to irreversible damage.

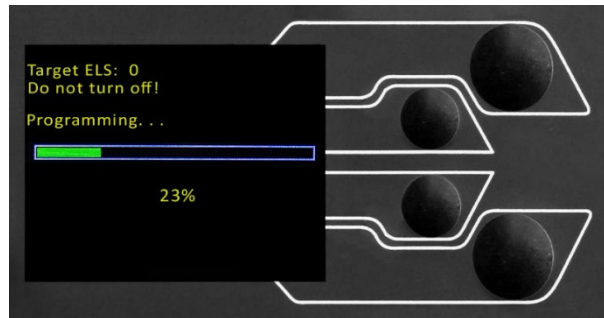

In the image above initial programming is taking place. You can monitor the progress using the bar and percentage readout shown onscreen.

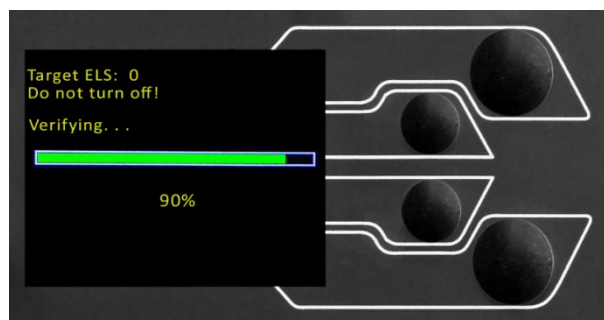

Within the final stage of the process, the firmware upgrade is verified to check that it has completed successfully.

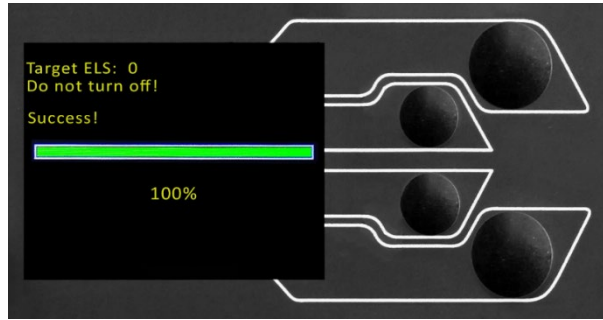

Once the process is at 100%, the display will indicate that the firmware upgrade has been successful.

Either you will then be prompted to update the next ELS device currently connected or the display will return to the start screen if no additional ELS devices are connected.

You can check the version of the ELS firmware manually by accessing the 'Information' screen located in the 'Settings' menu, **See Section 6** for more information.

## 7. MultiTest-dV Settings

---

### 7.1. MultiTest-dV Settings - dV Operation

The settings listed below are for a MultiTest-dV being used in dV mode, for dV(u) operation see 7.2.

#### Settings: Jog settings

Within the jog settings menu, you can configure the jog speed limits while in jog mode. Below is a detailed breakdown of each setting and the options available for each setting.

Setting	Action	Range
<b>Up Speed</b>	Configure the jog speed in an upward motion	0.1 to 1200 mm/min 0.004 to 47.24 Inch/min
<b>Down Speed</b>	Configure the jog speed in a downward motion	0.1 to 1200 mm/min 0.004 to 47.24 Inch/min
<b>Tension Limit</b>	Configure the tensile force limit while in jog mode	0 to +200 N
<b>Compression Limit</b>	Configure the compressive force limit while in jog mode	0 to -200 N
<b>Tare AFG/AFTI</b>	Configure whether or not the AFG/AFTI is tared when pressing the tare button in jog mode.	Yes or No

## Settings: Units

Within the units menu, you can configure the test stands units for displacement and speed. Force units are configured using the AFG.

Setting	Units Available
Displacement	mm, in
Speed	mm/min, mm/sec, in/min, in/sec
Force	N, gf, kgf, ozf, lbf, mN, kN

## Settings: Edit Test

### Important

For more information relating to 'Start Direction' and 'Move to Start', please see **MultiTest-dV Operation Sequence and Move to Start**.

### Displacement

In a displacement test, the crosshead moves between two reference points that are relative to tared zero. Ensure that the limit switches allow the required travel.

Setting	Options
Cycle Count	0-9999
Up Speed	0-1200mm/min
Down Speed	0-1200mm/min
Upper Displacement	A positive displacement is above tared zero and a negative value is below. Available displacement depends on the test setup.
Lower Displacement	A positive displacement is above tared zero and a negative value is below.

## Setting

## Options

**Start Direction** Choose whether the test direction is upward or downward.

---

**Move to Start** Select if the test moves to the start position first.

### Example

**Upper displacement:** +10 mm

**Lower displacement:** -20 mm

**Initial stroke:** Up

**Move to Start:** Yes

Unless already at -20 mm the crosshead will first travel to that point. The stand will then move to 10 mm above tared zero, followed by a final movement back to -20mm.

## AFG Control/Force Control

The AFG control test operation consists of two main functions:

- **AFG Control** - Control of the test stand using the AFG's limit or break settings,
- **Force Control** - Control of the test stand using the front panel to program limit, break or cycle settings,

Within AFG Control/Force Control there are four subtests:

## Sub-Test

## Description

**AFG Control** Move in a set direction until a force limit or break condition is hit and then stop. Configured using the AFG.

---

**Force Limit** Move in the configured direction until a force limit is hit and then stop. Configured using the front panel.

---

**Force Cycle** Cycle between a limit force and a return force. Configured using the front panel.

---

**Break** Move in the configured direction until a break condition is detected. Configured using the front panel.



## AFG Control Test

With an additional cable (351-092), a Mecmesin AFG digital force gauge can be used to set load limits to control crosshead movement.

Load setpoint, action (reverse/stop) are all set on the gauge under the 'STAND' menu. Here you can select the action when the limit is reached; 'REVERSE' or 'STOP' and the type of control limit 'BREAK' or 'LIMIT'.

Please note for cyclic tests the front panel force control must be used. AFG cycling is not compatible with MultiTest-*dV* test stands

### Example Test Setup

1. On the test stand's front panel under 'Edit Test' select the test type 'AFG Control' and sub-type 'AFG Control',
2. Configure the speed and direction settings located within the 'Edit Test' menu,
3. On the AFG gauge hold ,
4. On page one of the AFG menus select 'STAND' using  the button,
5. Next select the action when the limit is hit, either 'REVERSE' or 'STOP'. For reverse you need to select the test direction either 'UP' or 'DOWN',
6. Once the action has been selected configure the limit control. This limit can be either a 'BREAK' condition or force/torque 'LIMIT'. For 'BREAK' set the break threshold, for 'LIMIT' select the limit force/torque,

### Force Control Test - Force Limit, Force Cycle and Move to Break

Force control tests can be used to set load limits or a break condition to control crosshead movement.

Within the three sub-tests (Force Limit, Force Cycle and Move to Break) the following settings are available, please note some of the settings are specific to the test type:

Setting	Options
Up Speed	0-1200mm/min
Down Speed	0-1200mm/min

## Setting

## Options

**Start Direction** Choose whether the test direction is upward or downward.

---

**Test Sub-Type** Select the test sub-type (Options are listed above).

---

**Limit Force** **Limit and Cyclic Tests Only** - Enter the target load for the test.

---

**Return Force** **Cyclic Tests Only** - Enter the start load for the test.

---

**Cycle Count** **Cyclic Tests Only** - Enter the number of cycles to be completed.

---

**Break Threshold** **Move to Break Test Only** - Enter the percentage drop from current maximum load recorded, to activate the break detection.  
**Example:** Current load maximum reading is 1000N, with 80% setting the load drop must reach 200N before break detection activates.

---

**Min Break Threshold** **Move to Break Test Only** - Enter the minimum break threshold. Value of Load that the test load reading must rise above for a break condition to be detected.

- AFG must be connected and ON to set this parameter
- 1 % of AFG capacity is the lowest setting.

## Examples

### Force Limit

- **Up Speed:** 100 mm/min
- **Down Speed:** 100 mm/min
- **Start Direction:** Down
- **Test Sub-Type:** Force Limit
- **Limit Force:** 50 N

The crosshead moves down at 100 mm/min until the applied load is 50 N from tared zero, once the limit force is reached the test stops.

## Force Cycle

- **Up Speed:** 100 mm/min
- **Down Speed:** 20 mm/min
- **Start Direction:** Down
- **Test Sub-Type:** Force Cycle
- **Limit Force:** 200 N
- **Return Force:** 50 N
- **Cycle Count:** 10

The crosshead moves down at 20 mm/min until the applied load is 200 N from tared zero. Once the limit force is reached the crosshead moves upward at 100 mm/min until a load of 50 N is reached, this cycle repeats 10 times at which point the test stops.

## Break

- **AFG Capacity** 500 N
- **Up Speed:** 50 mm/min
- **Down Speed:** 100 mm/min
- **Start Direction:** Up
- **Test Sub-Type:** Break
- **Break Threshold:** 5 %
- **Min Break Threshold:** 10 N

The crosshead moves up at 50 mm/min until a break condition is detected. The drop in load must be at least 25 N (5 % of 500 N) and also occur above 10 N (2 % of 500 N), for the break detection to activate.

## Data Capture within VectorPro™

To use AFG Control/Force Control tests in conjunction with VectorPro first program the test settings using the stand's front panel and/or AFG and then create a VectorPro test using the AFG/Force control operation, ensuring the speed and test direction match your configuration.

Please note the speed and test direction use the settings configured within VectorPro, while other test settings are loaded from the front panel. For more information please refer to the VectorPro user manual, part no. 431-955.

## Limits

In a limit test, the crosshead cycles between the limit switches. To set your limit switches loosen either screw, located on the rear of the test stand, and move the switch to the required position.

A cycle starts when the crosshead is at the first limit switch and ends back at the same limit switch. At the end of the test, the home button appears on the stand to enable the crosshead to be moved back to the starting position.

Setting	Options
Cycle Count	0-9999
Up Speed	0-1200mm/min
Down Speed	0-1200mm/min
Start Direction	Choose whether the test direction is upward or downward.
Move to Start	Select if the test moves to the start position first.

## Example

1. Load your grips and sample,
2. Set the upper limit switch at the desired upper displacement point,
3. Set the lower limit switch at the desired lower displacement point,
4. Set the desired start direction and whether to move to start,
5. Configure the number of cycles,
6. Execute the test. The stand moves between the two displacements for the configured number of cycles and then stop.

## Half Cycle

A half-cycle test is to a displacement relative to tared zero. A cycle starts when the crosshead is at the first displacement position and ends back at the second position.

Setting	Options
Cycle Count	0-9999
Up Speed	0-1200mm/min
Down Speed	0-1200mm/min
Upper Displacement	A positive displacement is above tared zero and a negative value is below. Available displacement depends on the test setup.
Lower Displacement	A positive displacement is above tared zero and a negative value is below.
Start Direction	Choose whether the test direction is upward or downward.
Move to Start	Select if the test moves to the start position first.

### Example

**Upper displacement:** +30 mm

**Lower displacement:** -20 mm

**Initial stroke:** Down

**Move to Start:** Yes

Unless already at 30 mm above tared zero, the crosshead will travel to that point and then move to 20 mm below tared zero, and stop.

## MultiTest-*dV* Operation Sequence and Move to Start

MultiTest-*dV* operations, such as the displacement cycle and half cycle consist of two datum points, an upper displacement and a lower displacement.

For operations with the primary direction being down, the following is true:

- The 'Upper Displacement' is the start position for the test and the 'Lower Displacement' is the finishing position.

For operations with the primary direction, being up the following is true:

- The 'Lower Displacement' is the start position for the test and the 'Upper Displacement' is the finishing position.

Within the 'Edit Test' display on your test stands front panel there is an option called 'Move to Start', setting this feature to 'Yes' means that the stand always moves to the start position.

In some instances, this means the first direction of movement is opposite to the primary test movement.

For example, if the start displacement is +10 mm and the crosshead is at 0 mm, with move to start enabled a downward test will first move up to +10 mm before moving down to the end position. With this feature set to 'No', the stand moves straight to the end position.

## Settings: PIN Code

Within the PIN code menu, it is possible to set a four-digit number that can be used to lock the menu feature of your OmniTest Twin Column. Please note once this has been set you cannot access the menu without the PIN, so it is crucial that you keep a record of this safe. If the PIN code has been set and then lost or is unknown, please contact your local agent or Mecmesin Technical Support.

## Settings: Languages

Select your desired language. Upon confirmation, you are returned to the settings menu in the language chosen.

## Settings: Information

This screen is used to display vital information relating to your MultiTest-*dV* and connected devices. Here you can see software, hardware and firmware properties. If the stand is operating in *dV(u)* mode you can also see the calibration date for ELS and the number of overloads that have occurred for the current ELS.

## 7.2. MultiTest-dV Settings - dV(u) Operation

The settings listed below are for a MultiTest-dV being used in dV(u) mode, for standard dV operation see 7.1.

All settings are made by moving the selection marker to the required item or digit and confirming with the tick button or using the central scroll wheel button.

### Settings: Jog settings

Within the jog settings menu, you can configure the jog speed limits while in jog mode. Below is a detailed breakdown of each setting and the options available for each setting.

Setting	Action	Range
Up Speed	Configure the jog speed in an upward motion	0.1 to 1200 mm/min 0.004 to 47.24 Inch/min
Down Speed	Configure the jog speed in a downward motion	0.1 to 1200 mm/min 0.004 to 47.24 Inch/min
Tension Limit	Configure the tensile force limit while in jog mode	0 to +200 N
Compression Limit	Configure the compressive force limit while in jog mode	0 to -200 N

### Settings: PIN Code

Within the PIN code menu, it is possible to set a four-digit number that can be used to lock the menu feature of your OmniTest Twin Column. Please note once this has been set you cannot access the menu without the PIN, so it is crucial that you keep a record of this safe. If the PIN code has been set and then lost or is unknown, please contact your local agent or Mecmesin Technical Support.

### Settings: Information

This screen is used to display vital information relating to your MultiTest-dV and connected devices. Here you can see software, hardware and firmware properties. If the stand is operating in dV(u) mode you can also see the calibration date for ELS and the number of overloads that have occurred for the current ELS.

## 8. Rear Connectors Panel

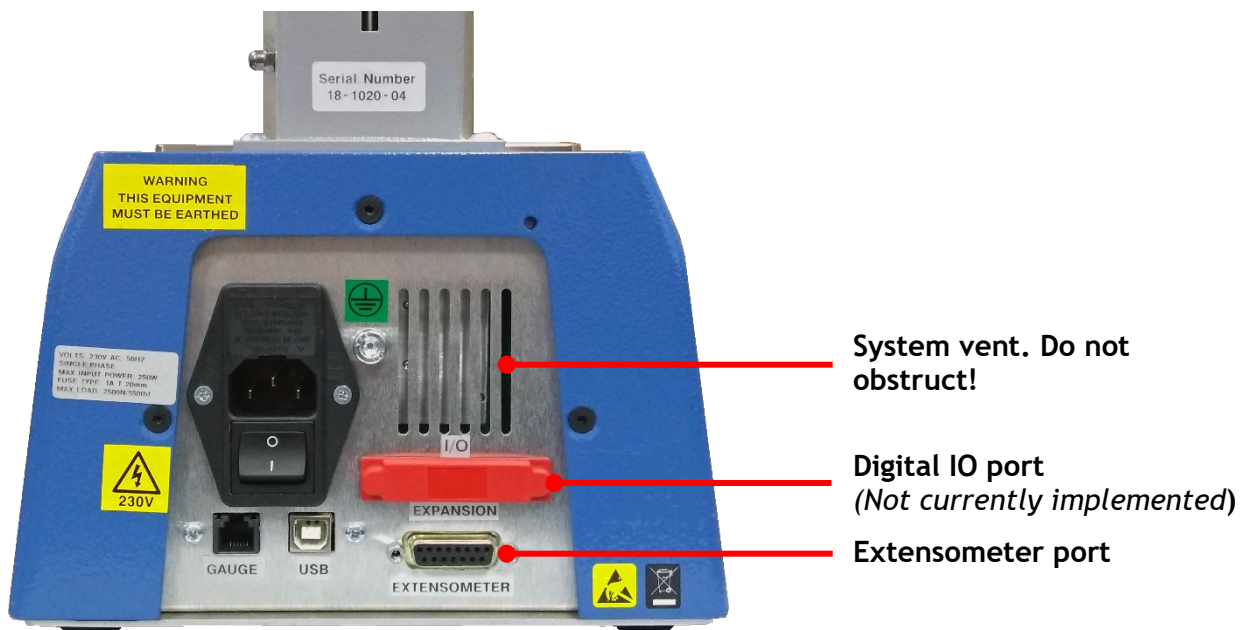
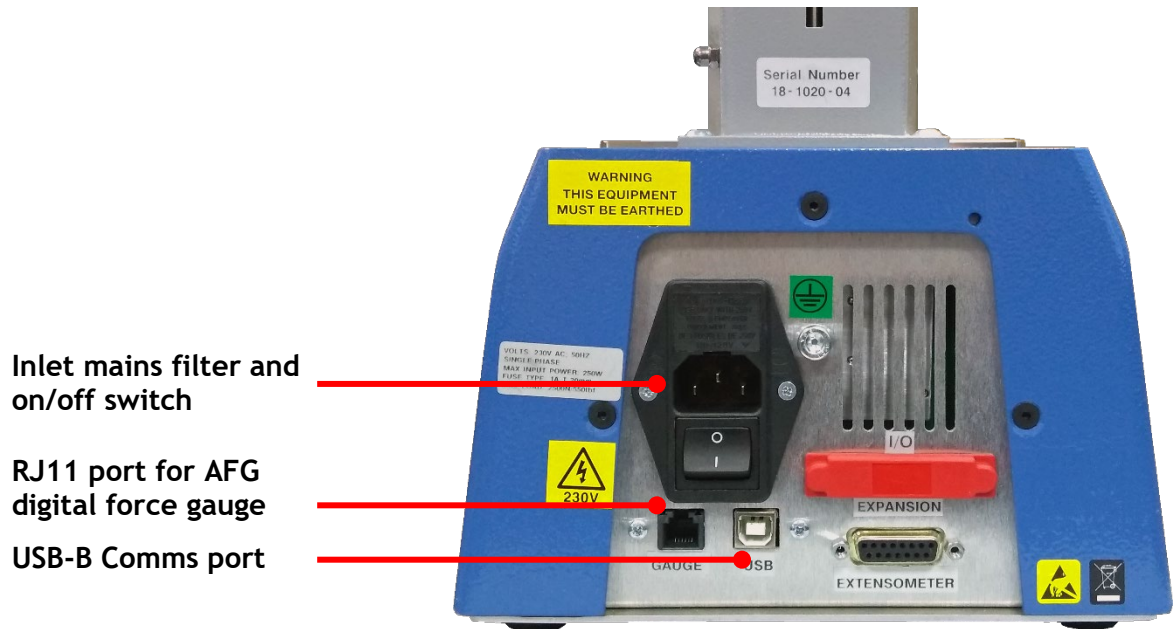

## 9. MultiTest-dV Specification

MultiTest-dV				
Rated capacity kN	kN	0.5	1.0	2.5
	kgf	50	100	250
	lbf	110	220	550
Displacement				
Crosshead travel*		1186mm (46.7")	986mm (38.8")	507mm (20")
Maximum headroom*		1205mm (47.4")	1005mm (39.6")	526mm (20.7")
Displacement resolution		1 $\mu$ m (0.000025")		
Displacement accuracy		$\pm$ 0.130mm per 300mm travel ( $\pm$ 0.005" per 11.81")		
Speed				
Speed range†	mm/min	0.01 to 1200	0.01 to 1200	0.01 to 1200††
	in/min	0.004 to 47.2	0.004 to 47.2	0.004 to 47.2
Speed accuracy		$\pm$ 2% of indicated speed or $\pm$ 20 $\mu$ /min whichever is greater***		
Resolution		0.1mm/min (0.004"/min)		
Maximum number of cycles per test		9999 (Cycling testing is not available in dV(u) mode)		
Dimensions				
Height		1616 mm (64")	1416 mm (56")	941 mm (37")
Width		290 mm (11.4")	290 mm (11.4")	290 mm (11.4")
Depth		414 mm (16.3")	414 mm (16.3")	414 mm (16.3")
Vertical daylight*		1267mm (49.9")	1067mm (42")	588mm (23.1")
Throat Depth**		70.5 mm (2.8")	70.5 mm (2.8")	70.5 mm (2.8")
Weight		31 kg (68 lbs)	27.5 kg (61 lbs)	24 kg (53 lbs)
Electrical supply				
Voltage		230 V AC 50 Hz or 110 V AC 60 Hz		
Maximum power requirement		120W	200W	250W
Advanced Force Gauge (AFG), 10 models from 2.5 N to 2500 N				
Sensor measurement accuracy		0.1% of full-scale		
Enhanced Load Sensors (ELS), 13 models from 2.5 N to 2500 N				
Sensor measurement accuracy		$\pm$ 0.5% of reading down to 5% of range		
Environment specification				
Operating temperature		10°C - 35°C (50°F - 95°F)		
Operating relative humidity		Normal Industry and laboratory conditions. (30% to 80% non-condensing)		
Display & Data Output				
Front Panel Display Indication		Load / Displacement / Speed		
Output of Test Results	Stand	Via USB (VectorPro™ Software - PDF, XLXS, CSV, TXT, Email and Images)		
	AFG / AFTI	Via Cable (sales@mecmesin.com)		

\* Measured with force gauge and short extension rod fitted

\*\* Measured on centreline of gauge/sensor

\*\*\* Machine wear can be expected over time and may potentially adversely affect both speed and displacement measurement. Machine wear is dependent on factors such as the frequency of usage, harsh operating environments, and the types of test performed (e.g., sudden breaks of stiff materials may cause energy recoil which affects mechanical parts etc.). A full overhaul of the test frame may be required to bring the test system back to its original manufacturer's specification.

† Where mains voltage is reliable

†† 2.5 kN : recommended maximum speed = 750 mm/min (30 in/min) above 2 kN

# 10. MultiTest-dV Dimensions

## MultiTest-dV 2.5kN Dimensions

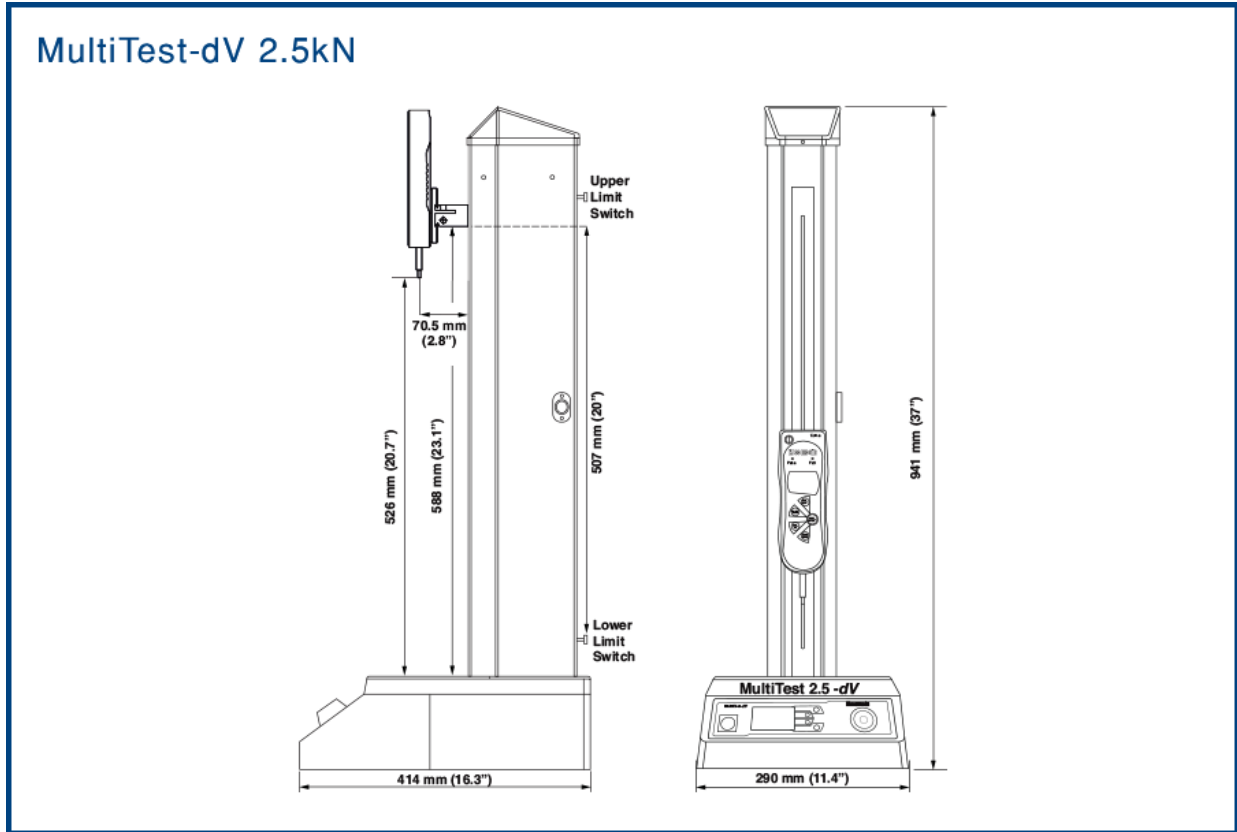

**Note:** The above drawing is not to scale!

## MultiTest-dV 1.0kN Dimensions

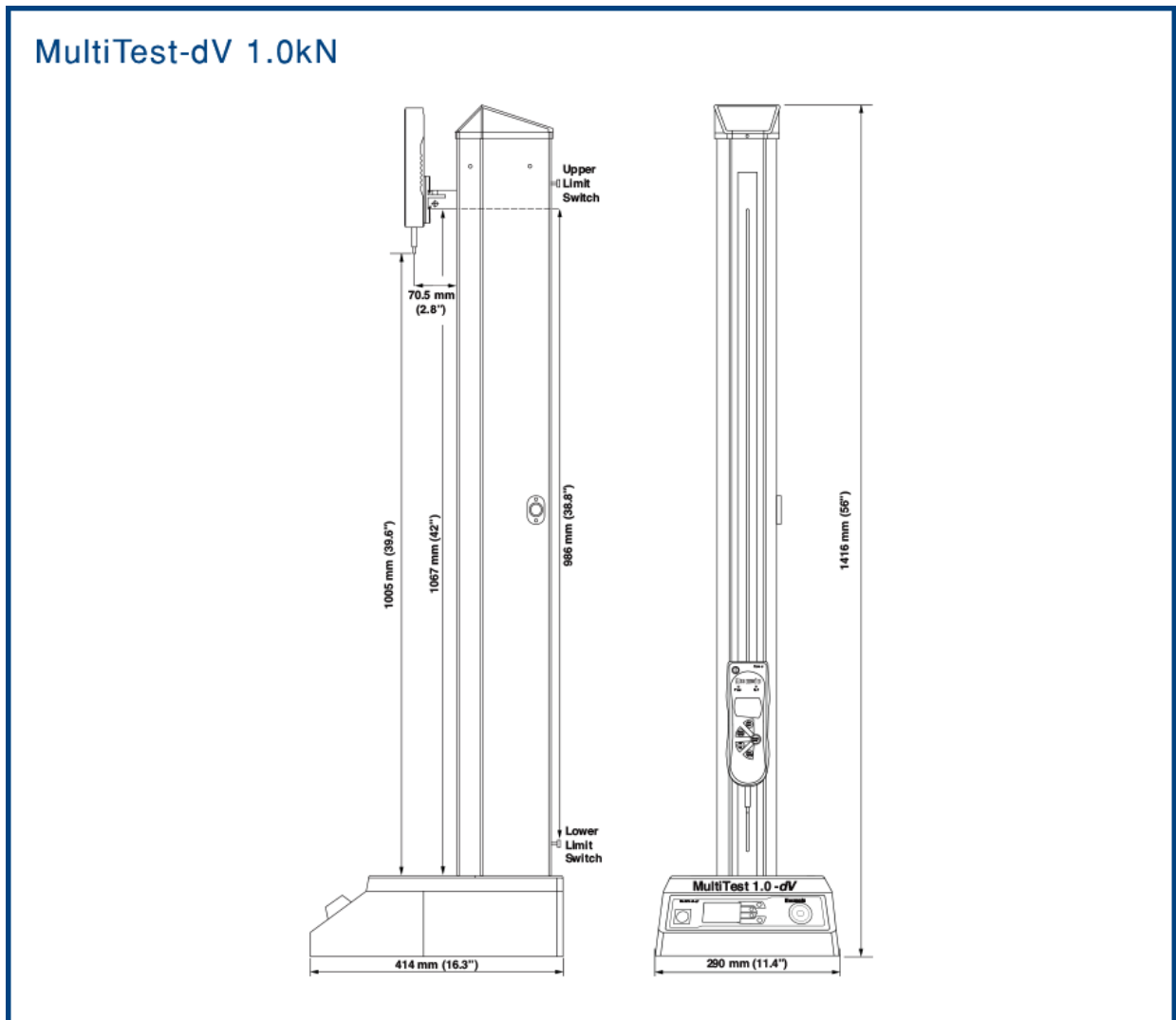

**Note:** The above drawing is not to scale!

## MultiTest-dV 0.5kN Dimensions

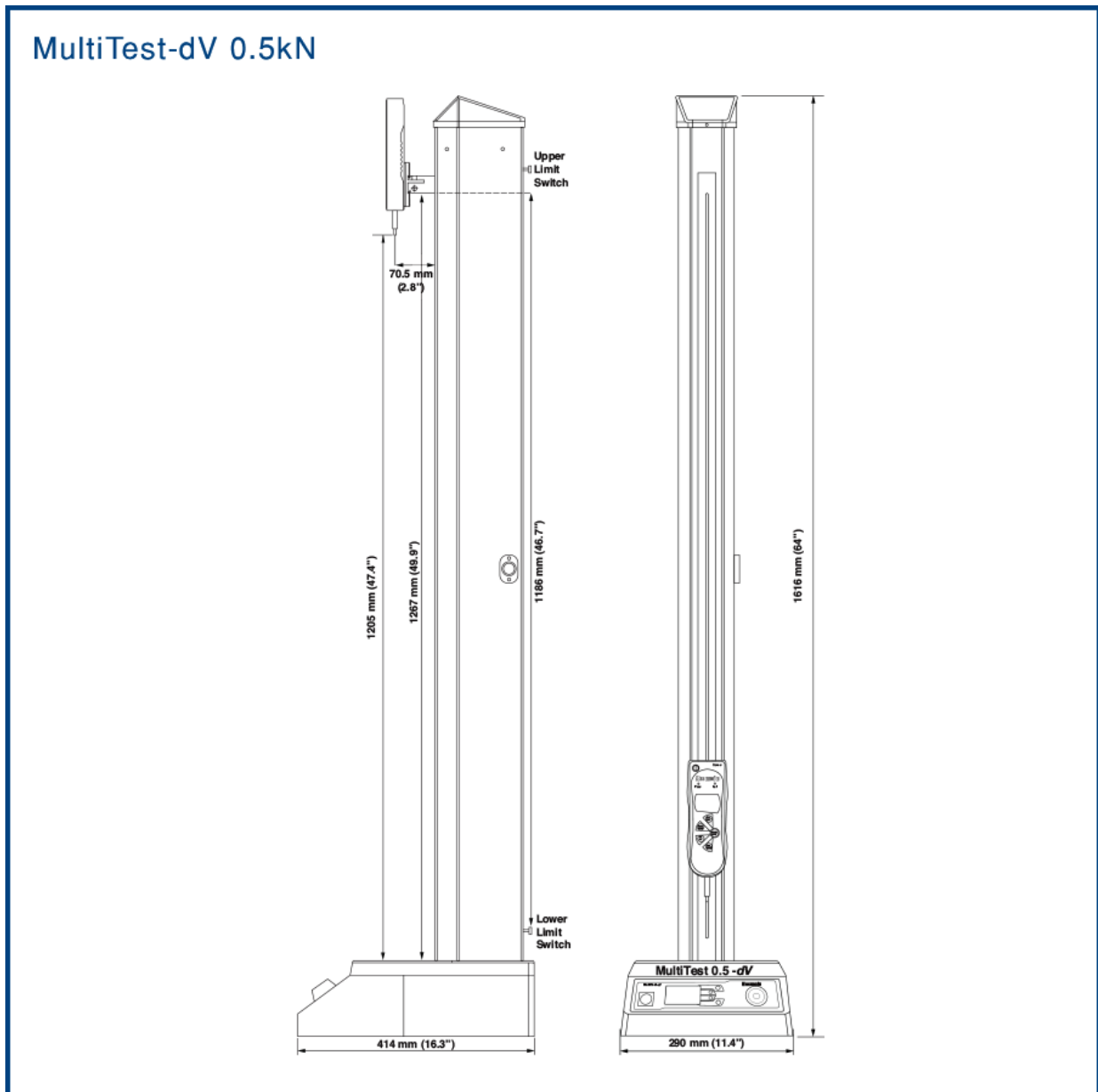

**Note:** The above drawing is not to scale!

# 11. Declaration of Conformity

Mecmesin Ltd  
Newton House  
Spring Copse Business Park  
Slinfold  
West Sussex, RH13 0SZ  
United Kingdom

**Mecmesin**  
FORCE & TORQUE TEST SOLUTIONS

Date of Issue 30<sup>th</sup> March 2018

## EC DECLARATION OF CONFORMITY

We confirm that the Technical Construction Files for the product(s) identified on this certificate comply with the essential safety requirements of the following EU Council directives. Technical documentation to support this is available from the above address.

- Machineries Directive 2006/42/EU
- EMC Directive 2014/30/EU

They were tested to the following standards and other normative documents:

- EN 61000-6-1:2007 Electromagnetic compatibility (EMC). Generic standards.
- EN 61000-4-3:2006 +A2:2010 Electromagnetic compatibility (EMC). Testing and measurement techniques.
- EN 60204-1:2006 +A1:2009 Safety of machinery. Electrical equipment of machines. General requirements
- EN 61010-1:2010 Safety requirements for electrical equipment for measurement, control, and laboratory use. General requirements
- EN 60950-1:2006 +A2:2013 Information technology equipment. Safety. General requirements

Primary Product Name(s): MultiTest-2.5dV

Derivative Product(s): MultiTest-0.5dV, MultiTest-1.0dV, MultiTest-2.5dVe,  
MultiTest-0.5dV(u), MultiTest-1.0dV(u), MultiTest-2.5dV(u),  
OmniTest 1.0, OmniTest 0.5

Signed on behalf of Mecmesin Ltd

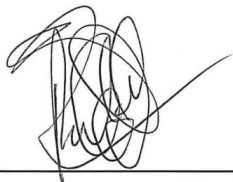

Technical Director: Patrick Collins



Registered in England No. 1302639

431-DoC24-01\_L00

# 12. Change Log

---

The latest production firmware release for MultiTest-*dV* devices is 3.0.10, this section documents the changes at each production firmware release from version 2.0.11 to 3.0.10. MultiTest-*dV* devices operating in *dV(u)* mode only use firmware version 3.0.2 or later.

Please note for version numbers not listed below the changes are included with the next version, for example, bug fixes in versions 3.0.4 to 3.0.5 are listed under in 3.0.6.

All releases include performance enhancements and bug fixes to improve the use experience. Not all bug fixes are detailed here.

## 2.0.12 - New Features

- N/A

## 2.0.12 - Bug Fixes

- Correction to AFTI Min/Max reset command.

## 3.0.2 - New Features

- System deflection compensation is implemented,
- Additional menu item 'Information' screen has been added,
- **Major Feature!** *dV(u)* mode implemented, enables MultiTest-*dV* test stands to support ELS and extensometry devices for basic material testing applications, provided the appropriate license key is used,
- **Major Feature!** User selectable PIN protection for the test stands menus added,
- **Major Feature!** 'Home' button added to return the stand to the last tared position at the end of the test,
- **Major Feature!** Within the jog settings, you can now to choose whether or not to tare the AFG/AFTI when pressing the stand's tare button,
- **Major Feature!** In the 'Edit Test Settings' menu, the user can select the test start direction and whether or not the stand moves to the start position at the beginning of the test,
- **Major Feature!** On 'AFG/AFTI' controlled tests, the return position is now the test start position rather than the limit switch position,
- **Major Feature!** AFG/AFTI stand control force limits now also work in jog mode, this can be used to protect damage to the system while jogging,

- **Major Feature!** You can now use the front panel control to pause, stop or continue the test,
- Swedish language option added,
- Polish language option added.

### 3.0.2 - Bug Fixes

- Fixed bug whereby ELS connection during jog mode will cause the stand to exit jog mode,

### 3.0.3 - New Features

- **Major Feature!** Add new command for setting the stands home position. This is exposed in VectorPro 5.1.2.0,
- Addition of 0.5 kN and 1.0 kN test stands as variants of 2.5 kN test stand,

### 3.0.3 - Bug Fixes

- Removed the ability to run tests when ELS 1 is not connected,
- Fixed no counts error when hitting limit switches at high speed.

### 3.0.6 - New Features

- N/A.

### 3.0.6 - Bug Fixes

- Resolved issue where overload counts are missing from the device firmware.

### 3.0.7 - New Features

- N/A.

### 3.0.7 - Bug Fixes

- Fixed issue where the AFG wasn't tared correctly,
- Fixed issue where an extensometer could create an overload that would terminate the test,
- Test not being terminated by over temperature reading has now been fixed,

### **3.0.8 - New Features**

- Force control tests are now programmed via the front panel (Previously via AFG),

### **3.0.8 - Bug Fixes**

- Fixed MultiTest-*dV* front panel decimal rounding/missing decimal issue (Force control),

### **3.0.10 - New Features**

- Force limits for AFG added to Jog Settings,

### **3.0.10 - Bug Fixes**

- Fixes Stop/Reverse function being ignored if AFG is not seen as connected
- Fix speed settings not updating in edit test menus
- Fix Load readings frozen in Move to Break test

# 13. Test Stand Firmware/ Software Compatibility Table

The tables below can be used to identify what versions of VectorPro can be used with your test stands firmware.

- To identify the firmware navigate to the information panel within the test stand's settings menu.
- The software version can be identified by clicking the VectorPro icon located in the centre of the top header bar or visually on the main login window.

**MultiTest-dV**

		Software Version				
		1.1.0.0 to 2.1.0.0	2.1.0.0 to 2.1.7.0	3.1.0.0	5.1.0.0 to 5.1.6.0	5.2.0.0
Device Firmware Version	2.0.8 or earlier	✓	✓	✗	✗	✗
	2.0.11	✓	✓	✗	✓	✗
	3.0.2	✗	✗	✗	✓	✗
	3.0.3	✗	✗	✗	✓	✗
	3.0.4	✗	✗	✗	✓	✗
	3.0.5	✗	✗	✗	✓	✗
	3.0.6	✗	✗	✗	✓	✗
	3.0.7	✗	✗	✗	✓	✗
	3.0.8	✗	✗	✗	✓	✓
	3.0.10	✗	✗	✗	✓	✓

**MultiTest-dV in dV(u) Mode**

		Software Version				
		1.1.0.0 to 2.1.0.0	2.1.0.0 to 2.1.7.0	3.1.0.0	5.1.0.0 to 5.1.6.0	5.2.0.0
Device Firmware Version	2.0.8 or earlier	N/A	N/A	N/A	N/A	✗
	2.0.11	✗	✗	✗	✗	✗
	3.0.2	✗	✗	✗	✓	✗
	3.0.3	✗	✗	✗	✓	✗
	3.0.4	✗	✗	✗	✓	✗
	3.0.5	✗	✗	✗	✓	✗
	3.0.6	✗	✗	✗	✓	✗
	3.0.7	✗	✗	✗	✓	✗
	3.0.8	✗	✗	✗	✓	✓
	3.0.10	✗	✗	✗	✓	✓

Please note the stand must a MultiTest-dV Mark 2 with a serial number after 17-1XXX-11 to operate in dV(u) mode



# Mecmesin

testing to perfection

## Mecmesin : a world leader in affordable force and torque testing solutions

Since 1977, Mecmesin has assisted thousands of companies achieve enhanced quality control in design and production. The Mecmesin brand represents excellence in accuracy, build, service, and value. In production centres and research labs worldwide, designers, engineers, operators, and quality managers endorse Mecmesin force and torque testing systems for their high performance across countless applications.

[www.mecmesin.com](http://www.mecmesin.com)



The Mecmesin global distribution network guarantees your testing solution is rapidly delivered and efficiently serviced, wherever you are.



### Head Office - UK

#### Mecmesin Limited

w: [www.mecmesin.com](http://www.mecmesin.com)

e: [sales@mecmesin.com](mailto:sales@mecmesin.com)

### North America

#### Mecmesin Corporation

w: [www.mecmesin.com/us](http://www.mecmesin.com/us)

e: [info@mecmesincorp.com](mailto:info@mecmesincorp.com)

### France

#### Mecmesin France

w : [www.mecmesin.com/fr](http://www.mecmesin.com/fr)

e: [contact@mecmesin.fr](mailto:contact@mecmesin.fr)

### Asia

#### Mecmesin Asia Co. Ltd

w: [www.mecmesin.com/th](http://www.mecmesin.com/th)

e: [sales@mecmesinasia.com](mailto:sales@mecmesinasia.com)

### Germany

#### Mecmesin GmbH

w: [www.mecmesin.com/de](http://www.mecmesin.com/de)

e: [info@mecmesin.de](mailto:info@mecmesin.de)

### China

#### Mecmesin (Shanghai) Pte Ltd

w: [www.mecmesin.com/zh](http://www.mecmesin.com/zh)

e: [sales@mecmesin.cn](mailto:sales@mecmesin.cn)